

07/2018

Mod: ICE510MWS-R2

Production code: G510W HC



Diamond
catering equipment



Modular ice maker - Granular system Daily production up to 430 kg

Hotel	██████████
Restaurant	██████████
Fast food	██████████
Bar	██████████
Disco	██████████
Fish market	██████████
Supermarket	██████████
Medical & SPA	██████████
Industry	██████████

► Position n°



► Features & Plus

- Granular ice - 80-82% dry
- 1l (water) - 1kg (ice) - only Air cooled
- AISI 304 SS Scotch Brite finish
- Tropical class +43°C
- Specific volume 1 m³ = 550 kg of ice
- Removable and cleanable air filter
- AISI 304 SS evaporator
- Air or water cooling system
- Easy cleanable internal rounded surfaces
- Dust-proof water basin
- RoHS Free
- Electromechanical operation
- ON-OFF rocker switch
- Rotation sensor on low speed shaft
- Automatic water charge
- Standard and special voltages
- Frame in INOX
- HFC Free



Removable and cleanable air filter



AISI 304 SS evaporator



Dust-proof water basin



Easy cleanable internal rounded surfaces



Frame in INOX

► Usable Bins

- Bin 240PE
- Bin 110
- Bin 200
- Bin 350
- Bin 550V DS
- Roller Bin 100
- Double Roller Bin 100
- Double Roller Bin 500
- Double Roller Bin 1200

► Prod. 24h

Air temp.	Air temp.		Water temp.		Kg	Lbs
	10° C	50° F	7° C	45° F		
10° C	50° F	7° C	45° F	430	948	
21° C	70° F	15° C	60° F	400	882	

► Certifications available for this model





Ice Flakes

G 510 HC



Modular ice maker - Granular system Daily production up to 430 kg

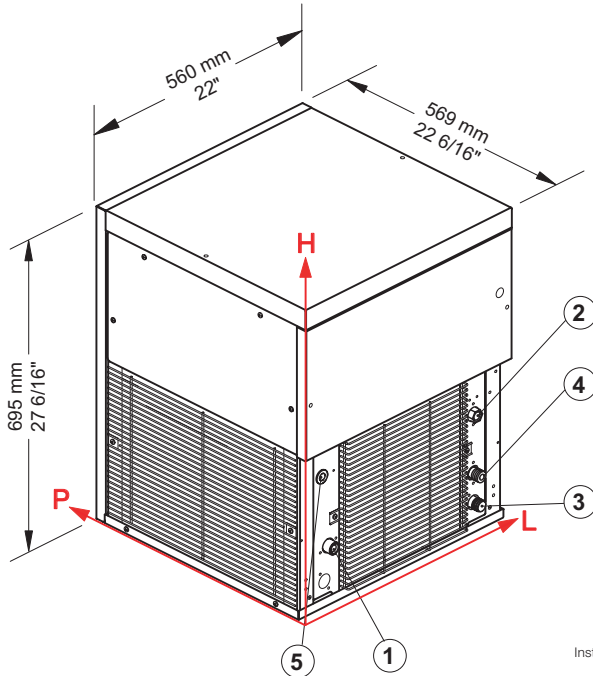

Installation



▶ Working conditions

- Location: **Indoor**

	Min	Max
Ambient temperature	+10° C / +50° F	+43° C / 110° F
Water temperature	+3° C / +37° F	+32° C / +90° F
Voltage	-10%	+10%
Water inlet pressure	1bar (14 psi)	6bar (84 psi)

▶ Performances

	Air temperature	Water temperature					
		7° C	45° F	15° C	60° F	21° C	70° F
	10° C	430 kg					
	50° F		948 lbs				
	21° C			400 kg			
	70° F				882 lbs		
	32° C					327 kg	
	90° F						721 lbs

▶ Connections

All measures are referred to the down-left corner (L-H-Ø)

- ① Water in.: 85,5 mm / 3 6/16" - 130 mm / 5 2/16" - 3/4"
- ② Cond. water in.: 479,5 mm / 18 14/16" - 260 mm / 10 4/16" - 3/4"
- ③ Water out.: 479,5 mm / 18 14/16" - 65 mm / 2 9/16" - 24 mm / 15/16"
- ④ Cond. water out.: 479,5 mm / 18 14/16" - 130 mm / 5 2/16" - 24 mm / 15/16"
- ⑤ Electrical connections: 67,5 mm / 2 11/16" - 290 mm / 11 7/16"
- ② ④ Only for water cooling systems

▶ Technical information

Production in 24h	400 kg / 882 lbs	Water consumption	A: 1 l/kg - 12,0 gal/100 lbs
Cooling system	A - W		W: 8 l/kg - 96 gal/100 lbs
Refrigerant	R290	Sizes (L-P-H mm)	560 - 569 - 695
Standard voltage	220-240 V ~ 50 Hz	(L-P-H in)	22 - 22 6/16 - 27 6/16
Average power consumption	1400 W	Sizes with pack (L-P-H mm)	645 - 645 - 910
Fuse	16 A	(L-P-H in)	25 6/16 - 25 6/16 - 35 13/16
Electrical consumption	10 kWh/100kg	Net weight	102 kg / 225 lbs
Finish	AISI 304 stainless steel, scotch brite	Gross weight	113 kg / 249 lbs

All the technical information need to be considered at the following conditions:

- Ambient temperature +21° C
- Water temperature +15° C
- Electrical consumption at +32° C (standard voltage)
- Average power consumption at +43° C (standard voltage)

Models and specifications are subject to change without notice

Rev. 02 - Issued April 2018