

Mod: **WR-SP41-A**

Production code: **SPRAY SK 45A**

# TECHNICAL SERVICE MANUAL

## ICE CUBE MAKERS

MODELS:

<u>SPRAY SK 25A</u>	<u>WR-SP24-A</u>
<u>SPRAY SK 45A</u>	<u>WR-SP41-A</u>

**CAREFULLY READ THE INSTRUCTIONS CONTAINED IN THIS MANUAL SINCE THEY PROVIDE IMPORTANT INFORMATION RELATIVE TO SAFETY DURING INSTALLATION, USE AND MAINTENANCE.**

---

**TABLE OF CONTENTS**

1. INTRODUCTION.....	3
1.1. Warnings.....	3
1.2. Description.....	4
1.3. Operating principle .....	4
1.4. Wiring diagram.....	7
2. SPECIFICATIONS .....	8
2.1. Installation diagrams for inlet/outlet tubes and dimensions .....	8
2.2. Consumption data, weights, crated dimensions and volumes .....	9
2.3. Production tables for Ice Flakers .....	11
3. DELIVERY & UNPACKING .....	14
4. INSTALLATION.....	16
4.1. Recommended placement of unit.....	17
4.2. Water and Drainage.....	17
4.3. Connecting unit to water source (water-cooler units) .....	18
4.4. Connecting unit to drain (water-cooled models).....	18
4.5. Electrical connection.....	18
5. OPERATION.....	19
5.1. Preliminary check .....	19
5.2. Starting up .....	19
6. ADJUSTMENTS.....	20
7. MAINTENANCE AND CLEANING INSTRUCTIONS.....	21
8. MAINTENANCE AND CLEANING PROCEDURES .....	22
8.1. Special advise concerning R-404 Refrigerant .....	25
9. TROUBLESHOOTING .....	26

---

## **1. INTRODUCTION**

### **1.1. Warnings**

This appliance should be installed by approved Technical Service Personnel.

This plug should be accessible at all times.

To reduce the risk of electrical shock, ALWAYS disconnect the machine BEFORE cleaning or maintaining the equipment. Do not attempt to install, service, or modify this machine. Improper use by other than specially trained technicians is extremely dangerous and may result in a fire or electric shock.

This machine should not be placed outdoors or exposed to rain.

Connect to drinking water mains.

This appliance is not intended for use by young children or infirm persons without supervision.

Young children should be supervised to ensure that they do not play with the appliance.

#### **IMPORTANT!**

- **DO NOT ATTEMPT TO SERVICE THIS MACHINE AS IT IS DANGEROUS AND COULD CAUSE SEVERE DAMAGE TO THE UNIT.**
- **SERVICE SHOULD ONLY BE CARRIED OUT BY TRAINED, QUALIFIED PERSONNEL.**
- **WE STRONGLY RECOMMEND USING ONLY ORIGINAL REPLACEMENT PARTS AVAILABLE FROM AN AUTHORIZED DISTRIBUTOR.**
- **WASTE AND OTHER MATERIAL SHOULD BE DISPOSED OF ACCORDING TO LOCAL REGULATIONS AND PROCEDURES FOR WASTE DISPOSAL.**
- **CLEANING AND MAINTENANCE ARE NOT COVERED BY THE WARRANTY.**

## 1.2. Description

### *Main Features of the Machine*

- Anti-blocking spray nozzles.
- Pump without seals.
- High pressure safety pressostats even in air-cooled machine.
- Large condensers (work well at high ambient temperatures; and reduce cooling water consumption in water-cooled machines).
- Transparents cubes.

## 1.3. Operating principle

WHEN SWITCHING ON THE MACHINE FOR THE FIRST TIME, THE MACHINE SHOULD BE PLACED ON THE DEFROSTING STAGE. To do so, turn the wheels on the timer until the microswitches are depressed. At this moment, the compressor is working; the water inlet valve and hot gas inlet valve are both open. The water bin fills with water, any excess is lost via the maximum level overflow. After a period of time controlled by the timer (3-4 minutes usually), the hot gas valve and water inlet valve are closed. The pump then sends water to the evaporator where the ices cubes are gradually formed.

The evaporation temperature slowly descends until it reaches the thermostat set point, which sets off the timer at this temperature for about 16 minutes. Once this time has elapsed, the defrosting stage (3-4 minutes) begins. The pump is off and the hot gas and water valves are open. Some water is sent to the top of the evaporator to help the cubes unstick.

Once the defrosting stage is over, the cycle begins again, and so it continues until the bin is full of ice, and contact between the bin thermostat situated at the top of the bin and the ice will stop the machine. The bin thermostat will never stop the machine in mid-cycle.

### **OPERATING PRINCIPLE FOLLOWING THE ELECTRIC DIAGRAM (TIMER ON DEFROST - MICROSWITCHES DEPRESSED)**

Current reaches the machine via the line connecting the blue (1) and brown (4) terminals. The brown wire connects the compressor and timer motor. The blue wire connects bin thermostat T1

---

which closes the circuit with 3. A different blue wire goes to 2 on terminal G1 which at this moment is connecting 1 and 4. A red wire connects bin thermostat T1 and micros G1 and G2 which close the circuit with 4 and provide current via G1 to the timer G.

At this point the following are connected:

- COMPRESSOR (S)
- WATER INLET VALVE (P)
- HOT GAS VALVE (Q)
- TIMER MOTOR (G)

After 2 to 4 minutes micros G1 and G2 will open and close circuits 1-2. Via terminal 2 on micro G2, current reaches the pump. Circuit 4 on micro G2 which provides current to the hot gas valve (Q) and water inlet valve (P) will be interrupted. Since the thermostat is between 1 and 3 the timer will receive no current. The compressor continues switched on.

Air-cooled machines have a fan (R) which is controlled by the pressostat (F). In water-cooled models without pressostatic valve, pressostat (J) opens and closes the condenser electrovalve (K).

Evaporator temperature decreases until the cycle thermostat (T2) set point is reached, at this temperature circuit 1-2 will be closed and timer motor (G) will switch on.

Once the cycle is over, the pins on the timer wheels will force the micros to change circuits, stopping the pump and opening the hot gas valve and water valve. The combined effect of hot gas and water sprayed on the top of the evaporator will release the ice cubes and change the position of the cycle thermostat (T2).

The ice production and defrosting cycle will continue until the ice storage bin is full, at which point cycle thermostat (T1) will disconnect the machine, but never during a cycle, but at the beginning of the defrosting stage, since during the production cycle, current will reach the pump via terminals 1-2 of micro G1.

The machine will remain disconnected until the level of ice in the bin drops below the thermostat because of ice consumption. At this point the machine will connect automatically.



# 1.4. Wiring diagram

LECTRICO/ELEC. DIAGRAM/SCHEMA ELETTRICO  
RISCHER SCHALTPLAN/SCHEMAS ELECTRIQUES

PRACTICO/PRACTICAL/PRAKTISCH/PRACTIQUE

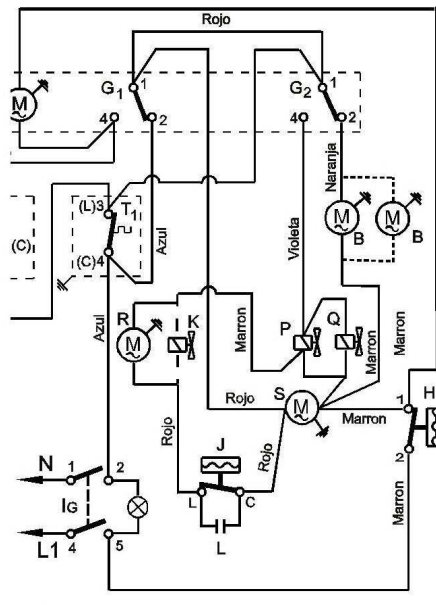

DESDE EL 11-02-09

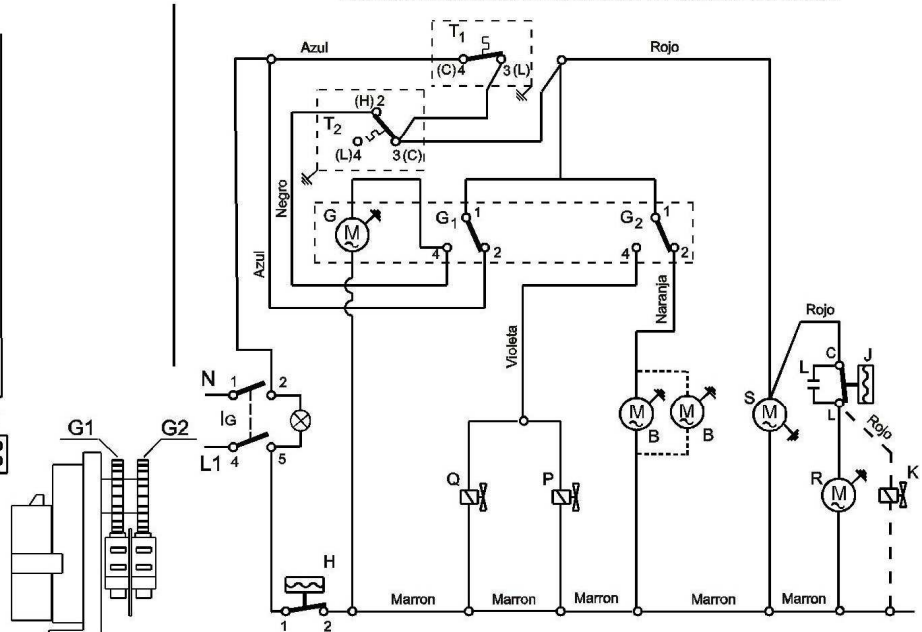

PROGRAMADOR

### COMPONENTES

- B Motor bomba
- F Presostato ventil. (solo aire)
- G Motor programador
- G1 Circuito segurid. programador
- G2 Circuito programador
- H Presostato seguridad
- J Presostato condens. (solo agua)
- K Electroval. condens.(solo agua)
- P Electroval. de agua
- Q Electroval. gas caliente
- R Motor ventilador
- S Compresor
- T1 Termostato almacen
- T2 Termostato ciclo
- L Condensador filtro
- r Resistencia 20W
- Ig Interruptor general
- ..... para ECO 100
- para cond. agua

### COMPONENTS

- B Motor pump
- F Fan pressostat (air)
- G Cam timer motor
- G1 Circuit safety timer
- G2 Circuit timer
- H Safety pressostat
- J Condens. pressostat (water)
- K Condens. electrov. (water)
- P Water electrovalve
- Q Hot gas electrovalve
- R Fan motor
- S Compressor
- T1 Stock thermostat
- T2 Cycle thermostat
- L Filter condenser
- r Resistance
- Ig Switch on/off
- ..... for ECO 100
- for water cond.

### BESTANDTEILE

- B Motorpumpe
- F Ventilatorpresostat (nur Luft)
- G Motorprogrammierer
- G1 Sicherheitsstromkreis des Program.
- G2 Stromkreis des Program.
- H Sicherheitspresostat
- J Kondensatorpresostat (nur Wasser)
- K Elektrov. des Kondens. (nur Wasser)
- P Elektrov. für das Wasser
- Q Elektrov. für warmes Gas
- R Motorventilator
- S Kompressor
- T1 Lagerthermostat
- T2 Zyklusthermostat
- L Kondensatorfilter
- r Widerstand
- Ig Schalter An/Aus
- ..... Für ECO100
- Für Wasser gekühlt

### COMPONENTI

- B Motore pompa acqua
- F Pressostato ventola (aria)
- G Motore timer
- G1 Sicurezza timer
- G2 Timer
- H Pressostato sicurezza
- J Pressostato sicurezza (acqua)
- K Electroval. condensatore(acqua)
- P Electroval. acqua
- Q Electroval. gas caldo
- R Motoventilatore
- S Compresore
- T1 Termostato contenitore
- T2 Termostato ciclo
- L Condensatore radio disturbi
- r Resistenza
- Ig Interruttore generale
- ..... per ECO 100
- per cond. acqua

### COMPOSANTS

- B Moteur pompe
- F Presostat ventilation (air)
- G Moteur programmeur
- G1 Programmeur securité circuit
- G2 Circuit programmeur
- H Presostat securité
- J Presostat condensation (eau)
- K Electroval. condensation (eau)
- P Electroval. eau
- Q Electroval. gaz chaud
- R Moteur ventilateur
- S Compresseur
- T1 Thermostat stock
- T2 Thermostat cycle
- L Condensateur filtre
- r Resistance
- Ig Interrupteur general
- ..... pour ECO100
- pour cond. eau

## 2. SPECIFICATIONS

### 2.1. Installation diagrams for inlet/outlet tubes and dimensions

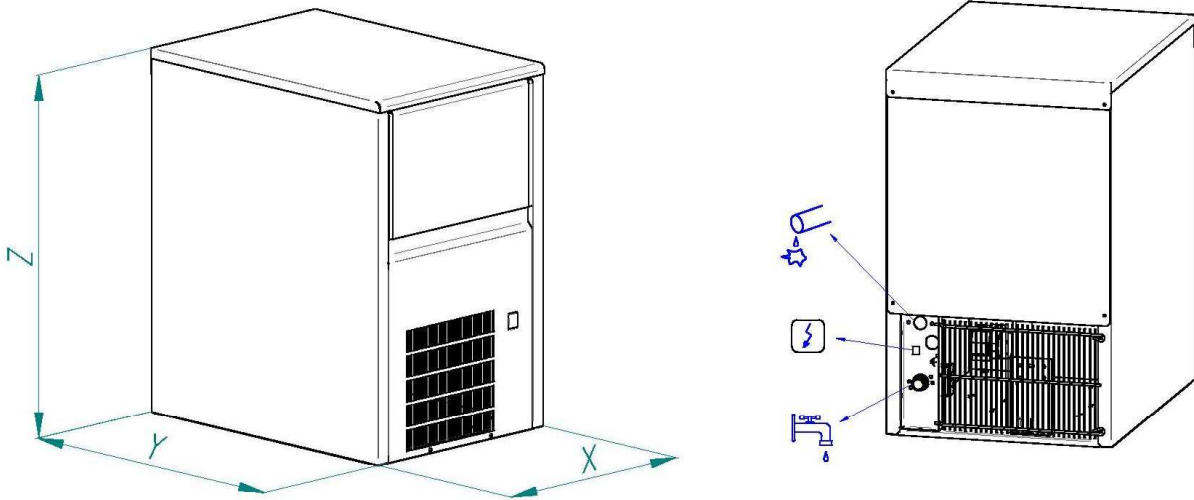

## 2.2. Consumption data, weights, crated dimensions and volumes

MODEL	WATER COND. L/Hour	WATER FABR. L/Hour	TOTAL L/Hour	WEIGHT NET (KG)	DIMENSIONS X*Y*Z	WEIGHT (KG)	DIMENSION (M <sup>3</sup> )
SPRAY SK 25A		5.1	<b>5.1</b>	34	350x470x590	40	0.20
25W	18	5.1	<b>23.1</b>	34	350x470x590	40	0.20
35A		14	<b>14</b>	42	435x605x695	50	0.26
35W	20	14	<b>34</b>	42	435x605x695	50	0.26
SPRAY SK 45A		18.2	<b>18.2</b>	44	435x605x695	52	0.35
45W	24	18.2	<b>42.2</b>	44	435x605x695	52	0.35
60A		28.8	<b>22.6</b>	54	515x640x830	65	0.40
60W	30	28.8	<b>58.8</b>	54	515x640x830	65	0.40
80A		14.6	<b>14.6</b>	64	645x640x860	75	0.48
80W	54	14.6	<b>68.6</b>	64	645x640x860	75	0.48
135A		17.2	<b>17.2</b>	134	930x565x1050	145	0.63
135W	59	17.2	<b>76.2</b>	134	930x565x1050	145	0.63

MODEL	REFRI. (GR)	HIGH PRESSURE				LOW PRESSURE Kg/cm <sup>2</sup>	(A)	FUSE SAFETY (A)	TOTAL CONSUMPTION (W)
		MIN		MAX					
		Kg/cm <sup>2</sup>	psi	Kg/cm <sup>2</sup>	psi				
SPRAY SK 25A	190	15	214	17	250	2.5	2	10	360
25W	190	15	214	17	250	2.5	2	10	360
35A	230	15	214	17	250	2.5	2.2	10	400
35W	270	15	214	17	250	2.5	2.2	10	400
SPRAY SK 45A	230	15	214	17	250	2.5	3.2	10	450
45W	270	15	214	17	250	2.5	3.2	10	450
60A	380	15	214	17	250	2.5	3.5	10	460
60W	350	15	214	17	250	2.5	3.5	10	460
80A	400	15	214	17	250	2.5	3	10	720
80W	380	15	214	17	250	2.5	3	10	720
135A	380	15	214	17	250	2.5	4.5	10	1150
135W	390	15	214	17	250	2.5	4.5	10	1150

### 2.3. Production tables for Ice Flakers

#### SPRAY SK 25A

Tw/Ta	45	40	35	30	25	20	15	10
35	6	8	10	12	13	13	14	14
30	9	12	13	15	16	17	17	17
25	12	15	16	18	19	20	20	20
20	15	17	19	20	22	22	23	23
15	17	19	21	23	24	25	25	25
10	19	21	23	25	26	26	27	27
5	21	23	25	26	27	28	28	28

#### 35

Tw/Ta	45	40	35	30	25	20	15	10
35	9	12	14	16	18	19	19	19
30	9	13	16	19	21	23	24	24
25	18	21	23	25	27	28	20	20
20	21	24	27	29	30	31	32	32
15	24	27	30	32	34	35	35	35
10	27	30	33	35	36	37	38	38
5	29	32	35	37	39	40	40	40

**SPRAY SK 45A**

Tw/Ta	45	40	35	30	25	20	15	10
35	11	15	19	21	23	24	25	25
30	17	21	25	27	29	30	31	31
25	23	27	30	32	34	36	36	36
20	27	31	35	37	39	40	41	41
15	32	35	39	41	43	45	45	45
10	35	39	42	45	47	48	49	49
5	38	42	45	48	50	51	52	51

**60**

Tw/Ta	45	40	35	30	25	20	15	10
35	14	19	23	26	28	30	31	31
30	21	26	30	33	36	37	38	38
25	28	33	37	40	42	44	44	44
20	34	38	42	46	48	50	50	50
15	39	43	47	51	53	55	55	55

10	43	48	52	55	57	59	60	60
5	46	51	55	58	61	62	63	63

**80**

Tw/Ta	45	40	35	30	25	20	15	10
35	19	26	31	36	39	41	42	42
30	29	36	41	46	49	51	52	41
25	38	45	50	54	58	60	61	61
20	46	53	58	62	66	68	69	69
15	53	59	65	69	72	75	76	75
10	59	65	71	75	78	80	81	81
5	63	70	75	80	83	85	86	86

**135**

Tw/Ta	45	40	35	30	25	20	15	10
35	30	40	48	55	60	63	65	64
30	45	55	63	70	75	78	80	80
25	59	69	77	84	89	92	94	93
20	71	81	89	99	101	104	106	105
15	81	91	100	106	111	115	116	116

10	90	100	109	115	120,	123	125	125
5	98	108	116	123	128	131	132	132

### **3. DELIVERY & UNPACKING**

Upon receipt, thoroughly inspect the packing container. If there appears to be damage to the container contact the shipper immediately. Unpack unit in the presence of delivery personnel noting any damage on the waybill.

ITV packing bears the “Green Point” on all models according to the European Directives on management of Packaging and Waste Disposal.

Be sure to include model name and serial number on all claims. Serial number is located in the following three places:

#### **(1) Packing**

There is a label stuck onto the cardboard packing bearing this serial number (1).

#### **(2) Machine body**

On the back of the machine (1).

#### **(3) Rating plate and serial number**

Located at the back of the machine.

Water cooled machines: check that the drainage hose at the back of the machine is in good condition. Verify that the installation kit is inside the bin, and has the following pieces: scoop, 3/4' water hose, two small filters and user manual.

In all models there is a large particle filter (5 micres) with accessories, and an ice dispersion cone.



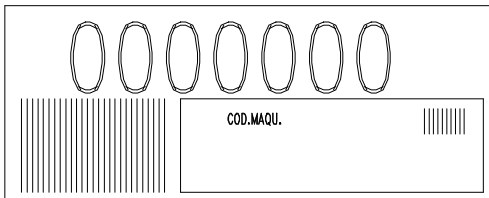
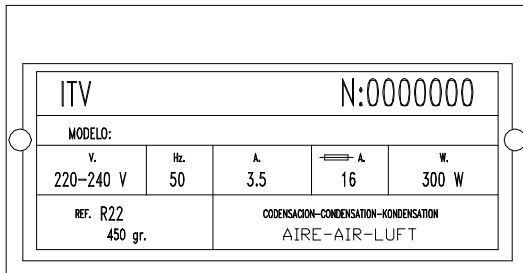

**WARNING: DO NOT LEAVE PACKING MATERIALS (PLASTIC BAGS, CARDBOARD BOXES, ETC.) WITHIN REACH OF CHILDREN.**

#### **4. INSTALLATION**

The ice cube maker is delivered on a small wooden pallet and is protected with a cardboard box and packaging. Loosen the cardboard box by cutting the straps, then lift vertically.

After having removed the packaging, make sure the machine is complete. If in doubt do not use it and go to the distributor who sold it to you.

This operation has to be performed with the wooden base structure firmly placed on the ground. All packaging elements (plastic bags, cartons, etc.) must not be left at children's reach, since they are a potential source of danger.

Place the machine where it is to be installed, and verify, using a level control, that the machine is in a horizontal position.

#### **IMPORTANT!**

If the gap between the back of the machine and the wall of the room/bar is not sufficient, or if it is going to receive hot air from another machine, we strongly advise you, in case of not being able to change the location of the machine, to **INSTALL A WATER-COOLED MACHINE.**

---

Bear in mind the previous considerations if the premises where the machines is located are very dusty, or smoky. If possible make arrangements so that the machine may be moved frontwise in order to carry out maintenance.

#### **4.1. Recommended placement of unit**

##### **IMPORTANT!**

ICETECH machines are intended to operate at room temperature between 5°C and 43°C and with water temperature ranging between 5°C and 35°C. You may encounter evaporator/gearbox malfunctions should the machine run at temperatures below the recommended minimum. When running above maximum recommended temperatures you can expect shorter compressor life and decreased production.

Air-cooled units receive air input via front of machine and expel air through rear grille.

##### **IMPORTANT!**

If front and/or rear ventilation is inadequate, obstructed, or in close proximity to other heat producing machinery, use of a water-cooled unit is strongly recommended.

The above mentioned also applies should unit be installed in an area where dust, smoke, or other airborne pollutants may be present. Units—especially air-cooled ones—should not be installed in kitchens. To facilitate access to condenser and/or water pressure valve, allow sufficient space at front of the machine. Ensure that flooring is firm and even.

#### **4.2. Water and Drainage**

Water quality influences ice hardness, flavour, and quality as well as condenser life.

Keep in mind the following points:

- a) **WATER IMPURITIES:** Major impurities are eliminated by filters provided. Filters should be cleaned regularly depending on purity of water. For minor impurities we recommend installing a 5-micron filter.
- b) **WATER WITH MORE THAN 500 PPM:** Ice will be less hard and tend to adhere. Lime deposits may impede proper functioning. In water cooled models, condenser obstruction is likely. Installation of a high quality water softener is recommended.

c) CHLORINATED WATER: Chlorine taste can be avoided by installing a carbon filter

**(NOTE: You may encounter water with all aforementioned properties.)**

d) PURIFIED WATER: A 10% reduction in overall production may occur.

#### **4.3. Connecting unit to water source (water-cooler units)**

- Use 1.3 m. flexible tube (with the two filters attached) provided. NOTE: We advise using a single faucet fixture.
- Water pressure should be between 0.7 and 6 Kgs/cm<sup>2</sup>. (10/85 Psi.)
- If water pressure exceeds these values, installation of appropriate corrective units will be necessary.
- It is important that water tubing does not come close to or in contact with any heat sources or heat generated by unit as this could decrease production.

#### **4.4. Connecting unit to drain (water-cooled models)**

- Drain must be located at least 150mm below machine level. Drain tube must have an inner diameter of 30mm and a minimum gradient of 3 cm per metre.

#### **4.5. Electrical connection**

- Unit is provided with a 1.5 m cord and Schucko socket.
- It is recommended to install a switch and adequate fuses. Nominal voltage and intensity are indicated on rating plate as well as on this manual's technical pages. Voltage fluctuations greater than 10% can cause problems or prevent machine from starting.
- Line to base of plug must have a minimum section=2.5 mm<sup>2</sup>.
- Be sure voltage indicated on rating plate corresponds to that of mains supply.

#### **IMPORTANT!**

Supply socket must be properly earthed. Be sure to check standard for country where appliance is going to be installed.

## 5. OPERATION

### 5.1. Preliminary check

- a) Is machine levelled?
- b) Are voltage and frequency of mains supply the same as indicated on rating plate?
- c) Is drainage system working properly?
- d) Is air circulation and room temperature adequate? (Air-cooled models)

#### AMBIENT TEMPERATURE

#### WATER TEMPERATURE

<b>MAXIMUM</b>	40° C	35° C
<b>MINIMUM</b>	5° C	5° C

- e) Is water pressure adequate?

<b>MAXIMUM</b>	0.7 Kg/cm <sup>2</sup>
<b>MINIMUM</b>	6 Kg/cm <sup>2</sup>

**ATTENTION:** Check that voltage and mains frequency is the same as in the rating plate.

### 5.2. Starting up

Once preliminary check has been completed (ventilation, connections, temperature, etc.), proceed as follows:

- 1) Open water faucet. Check for leaks.
- 2) Plug machine into electricity mains supply.
- 3) Push the (blue) switch found on the machina front side.
- 4) Ensure that there are no strange vibrations or scraping sounds
- 5) Check that the water curtain moves freely
- 6) Verify that spray nozzles are all working
- 7) After 10 minutes, check that the water bin has no leaks on the maximum level overflow.

8) At the cycle's end, there should be frost formed on the compressor inlet tube except for the last 50 mm.

## **IMPORTANT!**

Advise the final user on maintenance procedures which are not included in warranty, as well as those breakdowns caused by neglect of proper maintenance procedures.

## **6. ADJUSTMENTS**

### ***Condenser water valve pressostat***

This pressostat controls high pressure by opening and closing the condenser water valve. Differential is a fixed 1 Kg/cm<sup>2</sup> (14 psi.). The valve closes at 16 Bar (228 psi.) which is equivalent to a water exit temperature of 38°C. Below this pressure it will be difficult to unstick the cubes in the defrosting stage. Above this pressure, compressor life and ice production are both reduced. Pressure can be increased by turning the small screw on the pressostat clockwise. A full turn is equivalent to about 1.5 Bar.

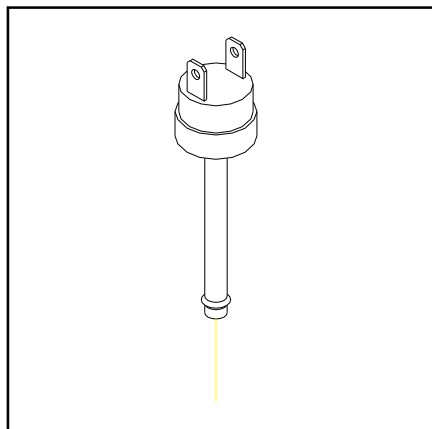

### ***Pressure Control***

#### ***Fan pressostat (air condensation)***

Pressure Control operates on high pressure by starting and stopping fan. Differential is a fixed (1Bar or 14 psi.) Cut-off pressure must be 16 Bar (228 psi.) Low pressure values may cause

gearbox malfunction. Pressure values higher than 16 Kg/cm<sup>2</sup> may shorten compressor life and diminish ice production.

Pressure can be regulated by rotating screw on Pressure Control Valve (clockwise to increase pressure). One full turn is equivalent to about 1.5 Bar.

### **Safety pressostat**

This safety device trips when pressure is too high. Pressure might reach the limit when:

- a) Air circulation is not sufficient, room temperature is too high, condenser is dirty or fan motor is broken. (air-cooled models)
- b) Insufficient water in the cooling circuit, inlet water temperature is too high or fan motor is broken (water -cooled models).

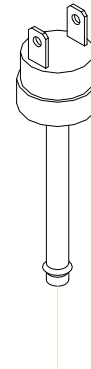

### **HIGH PRESSURE SET POINTS (non-adjustable):**

27-21 Kg/cm<sup>2</sup> (380-296 Psi.)

## **7. MAINTENANCE AND CLEANING INSTRUCTIONS**

### **IMPORTANT!**

\*\*Maintenance and cleaning procedures as well as problems derived from failing to carry them out are not covered by the warranty.

Proper maintenance is essential to obtain favourable ice quality and optimum functioning of unit. Frequency depends on water quality and characteristics of room where unit is installed.

### **IMPORTANT:**

\*\* Maintenance/cleaning procedures should take place at least once every six months. If concentration of air pollutants is high, complete procedures on a monthly basis.

**MAINTENANCE TABLE:**

PROCEDURE	MONTHLY	QUARTERLY	HALF YEARLY	YEARLY	BIENNIAL	DURATION
Air condenser cleaning	***	***	■■■	■■■	■■■	30 minutes
Water condenser cleaning				□□□	■■■	90 minutes
Injectors cleaning		□□□	□□□	■■■	■■■	30 minutes
Fabrication head filter cleaning			□□□	■■■	■■■	30 minutes
Water circuit cleaning		□□□	□□□	■■■	■■■	45 minutes
Sanitary cleaning		□□□	□□□	■■■	■■■	30 minutes
Water filter cleaning/replacement	□□□	□□□	■■■	■■■	■■■	30 minutes
Gearbox cleaning	◆◆◆	◆◆◆	◆◆◆	◆◆◆	◆◆◆	--
General unit cleaning	◆◆◆	◆◆◆	◆◆◆	◆◆◆	◆◆◆	--

\*\*\* Depending on room characteristics

□□□ Depending on water quality

◆◆◆ Carried out by owner

■■■ Essential

Maintenance and cleaning procedures as well as problems derived from failing to carry them out **ARE NOT COVERED BY THE WARRANTY.** Service personnel will invoice you for travel expenses, time invested and materials required for maintenance and cleaning of unit.

**8. MAINTENANCE AND CLEANING PROCEDURES**

**WARNING: Unit should always be disconnected during maintenance/cleaning procedures.**

**Water Condenser**

- 1) Disconnect machine.
- 2) Close water faucet.
- 3) Disconnect water entry/exit from condenser.

- 4) Prepare a solution of 50% phosphoric acid in distilled water.
- 5) Distribute solution through condenser. (Solution is more effective at 35°-40°C).

**WARNING!****DO NOT USE HYDROCHLORIC ACID*****Air Condenser***

- 1) Disconnect machine.
- 2) Close water faucet.
- 3) Clean condenser using a vacuum cleaner, soft brush and/or low-pressure air.

***Evaporator/Water Trough***

- 1) Disconnect machine.
- 2) Remove drain plug situated in lower bearing.
- 3) Use a container to collect water. Allow water to flow for 2 to 3 minutes.
- 4) Close water entrance and replace plug. Prepare a solution of 50% phosphoric acid in distilled water.

*Do not use hydrochloric acid.*

- 5) Slowly pour solution into water deposit. (Solution is more effective at 35°-40°C).
- 6) Let solution stand for 20 minutes.
- 7) Remove lower plug and empty deposit.
- 8) Replace plug.
- 9) Fill container with solution to maximum capacity.
- 10) Connect machine and wait for unit to automatically shut off when remaining liquid drains.

**WARNING:\*\* Discard ice produced during cleaning procedure.**

- 11) Disconnect machine.
- 12) Remove plug.
- 13) Open faucet and let water run for 2 to 3 minutes.
- 14) Close faucet, place plug, open faucet and connect the machine.

**\*\*At this point sanitary cleaning starts**

- 15) Slowly add bleach to water deposit for at least 5 minutes.

16) Allow machine to make ice for at least 15 minutes.

WARNING:\*\* Discard ice produced during cleaning procedure.

17) Disconnect unit, place cover and check for water leaks.

18) Change joint in water plug if necessary.

19) Replace filters if necessary. (Machines provided with 5mm filters).

20) Reconnect machine.

### ***Cleaning the ice bin***

1) Unplug the machine, turn off water supply, and empty storage bin of ice

2) Wipe with a kitchen cloth soaked in bleach and detergent

3) If white lime stains do not vanish, rub with some lemon or vinegar, wait for a few minutes and wipe with the cloth again.

4) Rinse with plenty of water, dry, and run the machine

### ***Cleaning the outside of the machine***

Follow the same procedure as for the ice bin.

### ***Spray nozzles and connecting pipes***

1) Remove the curtain (it can be cleaned with vinegar or phosphoric acid, rinse, clean with bleach, rinse)

2) Remove the metal grill and clean likewise

3) Pull the connecting pipe upwards with some force.

4) Remove the spray nozzles by pulling them out one by one from the square pipe, and remove the pipe ends. Clean everything

5) Pull out the round wire mesh filter with some force.

6) Put everything back together again.

ATTENTION; IT IS ESSENTIAL THAT SPRAY NOZZLES ARE COMPLETELY PERPENDICULAR, OTHERWISE SOME CUBES MAY NOT BE FORMED WELL.

7) Place the grill over the nozzles, with the back spots secure.

8) Install the curtain, ensuring that all of the strips can move freely.

9) Run the machine but discard the first set of ice cubes.

### ***Cleaning the water inlet filters***

These round wire gasket filters placed on either end of the water hose to mains, often become blocked in the first few days of use, especially when the plumbing installation is new. Clean them under a jet of water.

### ***Checking for water leaks***

This must be done whenever maintenance is carried out on the machine: check all water connexions, braces, tubes and hoses in order to eliminate leaks and prevent breakages and flooding. Check that the valve closes tightly on models with an automatic cleaning system.

## **8.1. Special advise concerning R-404 Refrigerant**

- R-404 is a mixture of 3 liquid-phase gases. On evaporating, the 3 component gases separate
- Always use the liquid phase valve (at the end of condenser or accumulator) for refills and purges.
- When replacing a compressor, wash inside of circuit with a suitable solvent + pump, dry with nitrogen gas, REPLACE THE DRIER WITH ONE SUITABLE FOR R-404, which must also have ANTI-ACID properties.
- If you need to add oil, use one which is specific for R-404 (POE). If you are in doubt, contact the machine manufacturer.
- If there is a leak anywhere in the circuit where R-404 in the GAS phase, and a refill of over 10% is required, then ALL THE GAS IN THE CIRCUIT MUST BE PURGED AND THEN REFILL AS DESCRIBED PREVIOUSLY (LIQUID PHASE VALVE)
- When charging via low-pressure valve, do not start compressor immediately, allow about one hour for liquid to gasify.

## 9. TROUBLESHOOTING

PROBLEM	POSSIBLE CAUSES	SOLUTION
1) None of the electrics work.	A) The machine is not plugged in.	A) Plug the machine.
	B) The line fuse has blown.	B) Replace fuse.
	C) The current line is wrongly connected in the junction box.	C) Check connections.
	D) The cut off micro-switch is faulty or wrongly adjusted.	D) Check, adjust or change.
	E) Safety pressostat faulty.	E) Replace.
2) All the electrics work except compressor.	A) Loose wire.	A) Check connections.
	B) Faulty relay .	B) Replace relay.
	C) Faulty "Klixon".	C) Replace Klixon.
	D) Faulty compressor.	D) Replace compressor.
3) All the electrics work but the compressor "klixons" (cycles intermitently).	A) Voltage too low.	A) Check voltage.
	B) Dirty condenser.	B) Clean condenser.
	C) Obstruction in air circulation.	C) Move machine to a correct position.
	D) Fan has broken.	D) Replace fan.
	E) Starter capacitor faulty.	E) Replace condenser.
	F) Fan presostat faulty or wrongly adjusted.	F) Replace or adjust presostat.
	G) Water presostat valve faulty or wrongly adjusted.	G) Replace or adjust.
	H) Cooling water pressostat is faulty or badly adjusted.	H) Adjust or change.
	I) Cooling water entry valve is faulty.	I) Change.
	J) Non-condensable gases in system.	J) Purge system.
4) Everything appears to be running correctly but no ice is being made in the evaporator.	A) Unprimed pump.	A) Check overflow, water bin for leaks, water entry valve and prime the pump.
	B) Faulty pump.	B) Replace.
	C) Water does not enter into the bin.	C) Check water entry valve and change if is necessary.
	D) There is water in the gas circuit.	D) Replace the drier, empty the refrigerant (vacuum) and charge new refrigerant.
	E) Water tray is dry.	E) Check overflow pipe and for leaks. Inspect draining valve in machines with automatic cleaning system.
	F) Freezing system is faulty (dirty condenser, water presostat or entrance valve faulty or wrongly adjusted insufficient refrigerant.	F) Clean condenser, check all the system components: pressostat, water inlet valve, refrigerant charge, etc.
5) Ice cubes form correctly but do not unstick.	A) Water inlet filters dirty.	A) Clean filters on both ends of water hose to mains.

PROBLEM	POSSIBLE CAUSES	SOLUTION
	B) Low water pressure.	B) Increase water pressure if possible. (This can often be done by removing flowmeter on faucet).
	C) Faulty fan or pressostat.	C) Check fan and re-adjust pressostat or replace.
	D) Inlet cooling water valve.	D) Check and replace (water-cooled models only) if faulty.
	E) Pressostat is faulty.	Adjust (40-43°C), repair/replace (w-cooled models).
	F) Room or water temperature below 7°C	F) Add one pin to each timer wheel, in order to increase the unstick time.
	G) Faulty micro or timer.	G) Replace
	H) Production cycle too long.	H) Adjust cycle thermostat to increase the unstick time.
	I) Hot gas valve does not open.	I) Check valve.
6) Low ice production.	A) Blocked condenser or air access to condenser.	A) Clean condenser; improve air circulation by lifting machine from floor and moving away from walls and hot air sources .
	B) In water-cooled machines:dirty condenser, badly adjusted valve, pressostat, faulty water inlet valve or faulty pressostatic valve.	B) Clean condenser; check, adjust or replace.
	C) Faulty hot gas valve, doesn't close totally.	C) Replace.
	D) Faulty fan or pressostat, faulty inlet cooling water valve.	D) Check fan and re-adjust pressostat or replace.
	E) Refrigerant charge too high or too low.	E) Adjust.
	F) Faulty water inlet valve: leaks and does not close fully.	F) Check and replace.
	G) Inefficient compressor.	G) Replace.
7) Ice cube are so large that they stick together and form a slab or plate of ice (especially in very low ambient and water temperatures).	A) Cycle thermostat is too low or faulty.	A) Adjust or change.
	B) Timer wheels do not turn.	B) Tighten screws on timer.
	C) Timer motor is faulty.	C) Check and replace.
	D) Micros on timer are faulty.	D) Replace, check for bridging.
8) Ice cubes are too large (especially in low ambient and water temperatures).	A) Cycle thermostat is adjusted too high.	A) Adjust until desired cube size.
9) Ice cubes are too small, and empty (especially in high ambient and water temperatures).	A) Cycle thermostat is adjusted too low.	A) Adjust until desired cube size.
	B) Low refrigerant charge.	B) Add refrigerant until there is frost formation 5 cm from the compressor at the end of the cycle.

10) Ice cubes are empty, rough edges and very white.	A) Insufficient water in water pan; unprimed pump.	A) Correct a major water leak.
	B) Obstructed spray nozzles.	B) Clean.
	C) Curtain does not close fully.	C) Adjust the curtain, clean scale (lime) on curtain metal axis.
	D) DP 90 and 140 only: buoy and valve mechanism is obstructed.	D) Check, clean and replace.
11) Machine doesn't stop even when bin is full.	A) Faulty or badly adjusted bin thermostat.	A) Adjust and replace if necessary.
12) Ice cubes melt in bin.	A) Obstruction in drains (within machine or in premises).	A) Unblock.