

07/2018

Mod: ICE160MAS-R2

Production code: G160A HC



Diamond
catering equipment

SCHEMA ELETTRICO / WIRING DIAGRAM / ESQUEMA ELECTRICO

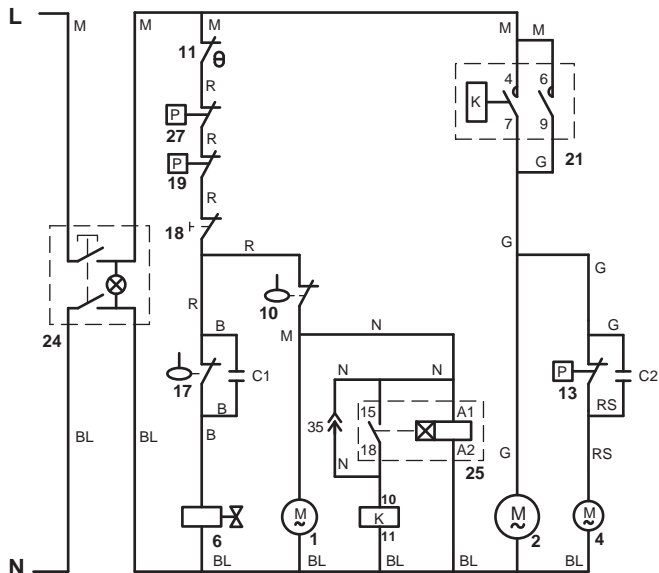

VERSIONE AD ARIA / AIR COOLED / VERSIÓN AIRE

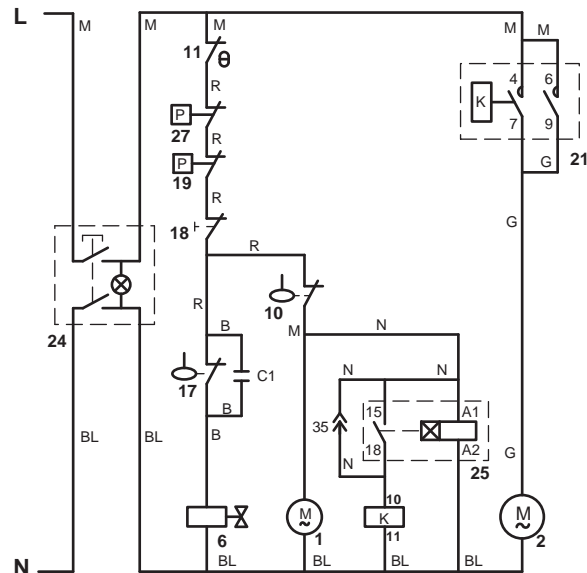

VERSIONE AD ACQUA / WATER COOLED / VERSIÓN AGUA

1. MOTORIDUTTORE GEAR MOTOR MOTOREDUCTOR	11. TERMOSTATO CONTENITORE BIN THERMOSTAT TERMOSTATO CONTENEDOR	21. RELE COMPRESSOR RELAY RELE'	B = BIANCO / WHITE / BLANCO BL = BLU / BLUE / AZUL G = GRIGIO / GREY / GRIS M = MARRONE / BROWN / MARRÓN N = NERO / BLACK / NEGRO R = ROSSO / RED / ROJO RS = ROSA / PINK / ROSA
2. COMPRESSORE COMPRESSOR COMPRESOR	13. PRESSOSTATO CONDENSAZIONE FAN CYCLE CONTROL PRESÓSTATO CONDENSACIÓN	24. INTERRUPTORE ON-OFF ON-OFF SWITCH INTERRUPTOR ON-OFF	
4. MOTOVENTILATORE FAN MOTOR MOTOVENTILADOR	17. MICRO LIVELLO ACQUA BACINELLA WATER LEVEL SWITCH MICRO NIVEL AGUA BACÍA	25. TIMER ELETTRONICO COMPRESSOR TIME DELAY TIMER ELECTRONICO	
6. VALVOLA ACQUA BACINELLA WATER INLET VALVE VÁLVULA AGUA BACÍA	18. MICRO DI SICUREZZA CHUTE SAFETY SWITCH MICRO DE SEGURIDAD	27. PRESSOSTATO DI SICUREZZA L.P. LOW PRESSURE SAFETY SWITCH PRESÓSTATO DE SEGURIDAD B.P.	
10. MICRO MANCANZA ACQUA BACINELLA LOW WATER LEVEL SWITCH MICRO FALTA DE AGUA BACÍA	19. PRESSOSTATO DI SICUREZZA H. P. H. P. SAFETY PRESSURE SWITCH PRESÓSTATO DE SEGURIDAD A. P.	35. BY-PASS TEMPO ATTESA - SOLO MANUTENTORE DELAY BYPASS - SERVICE STAFF ONLY BY-PASS ESPERA - SOLO MANTENEDOR	