

11/2016

Mod: ICE42 DISP W



Diamond
catering equipment

SCHEMA ELETTRICO / ELECTRIC DIAGRAM

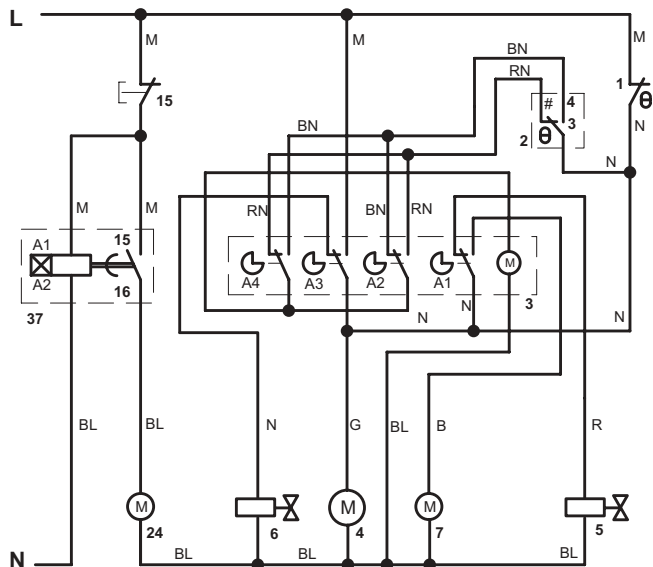

VERSIONE AD ARIA / AIR COOLED

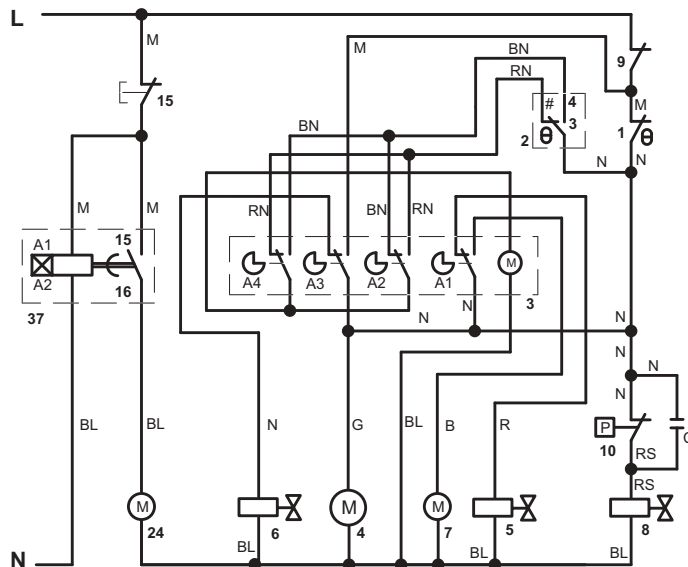

VERSIONE AD ACQUA / WATER COOLED

1. TERMOSTATO CONTENITORE BIN THERMOSTAT	6. ELETTROVALVOLA INGRESSO ACQUA PER EVAPORATORE WATER INLET VALVE FOR EVAPORATOR	15. MICROINTERRUTTORE NORMALMENTE CHIUSO MICRO SWITCH NORMALLY CLOSED
2. TERMOSTATO EVAPORATORE EVAPORATOR THERMOSTAT	7. POMPA PUMP	24. MOTORIDUTTORE EROGAZIONE CUBETTI ICE CUBES DELIVERY GEAR MOTOR
3. TEMPORIZZATORE TIMER	8. ELETTROVALVOLA INGRESSO ACQUA PER CONDENSATORE WATER INLET VALVE FOR CONDENSER	37. TEMPORIZZATORE EROGAZIONE GHIACCIO ICE DELIVERY TIMER
4. COMPRESSORE COMPRESSOR	9. TERMOSTATO DI SICUREZZA SAFETY THERMOSTAT	
5. ELETTROVALVOLA GAS CALDO HOT GAS VALVE	10. PRESSOSTATO PRESSURE SWITCH	

B = BIANCO / WHITE
BL = BLU / BLUE
BN = BIANCO-NERO / WHITE-BLACK
G = GRIGIO / GREY
M = MARRONE / BROWN
N = NERO / BLACK
R = ROSSO / RED
RN = ROSSO-NERO / RED-BLACK
RS = ROSA / PINK
6 = RANCO K59
2 = ATEAA33 - RANCO K61 - RANCO K22